

PAUL SCHERRER INSTITUT



Wir schaffen Wissen – heute für morgen

SETAC Europe 25th Annual Meeting

Integrating LCA and Scenario Modelling of the Energy System for Sustainable Policy-making

Kathrin Volkart

Laboratory for Energy Systems Analysis, Paul Scherrer Institute (PSI), Switzerland

- Motivation
- Methodologies and concept
- Integration of Global MARKAL model and LCA
- Outlook

- The world faces various challenges related to the energy system, e.g.
 - Climate change
 - Resource depletion
 - Energy access
 - Security of supply
 - Ecosystem damages
 - Human health damages
- Addressing one of the challenges mentioned above may influence (the solution of) other challenges. This leads to complex decisions for (energy) policy-makers.
- Therefore, integrated and consistent assessment methodologies are required for decision support and for the transition to sustainable energy systems.



- Motivation
- Methodologies and concept
- Integration of Global MARKAL model and LCA
- Outlook

Environmental assessment of single energy technologies and processes

- Included: detailed environmental and human health criteria
- Not included: dynamic temporal development, complete energy system

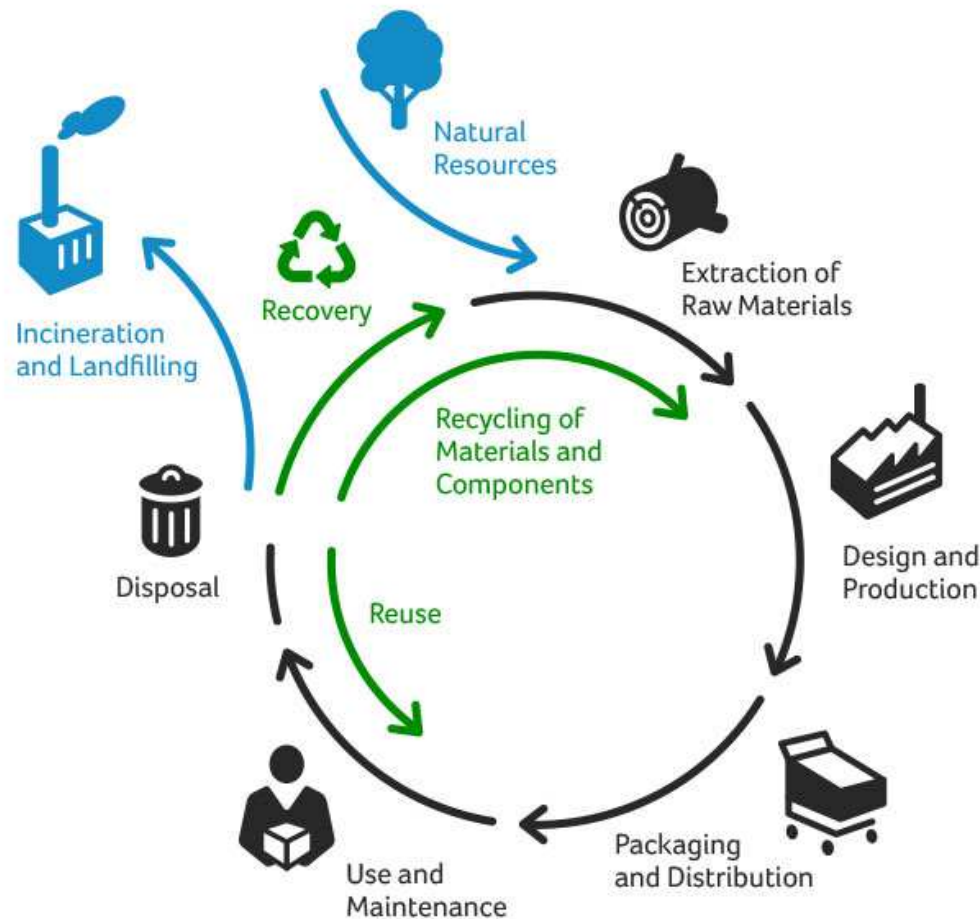

Source: www.ecoinvent.org

Developing, quantifying and analyzing scenarios of the energy system

- Included: system perspective, dynamic temporal development, techno-economic data
- Not included: other sustainability criteria (environment, human health)

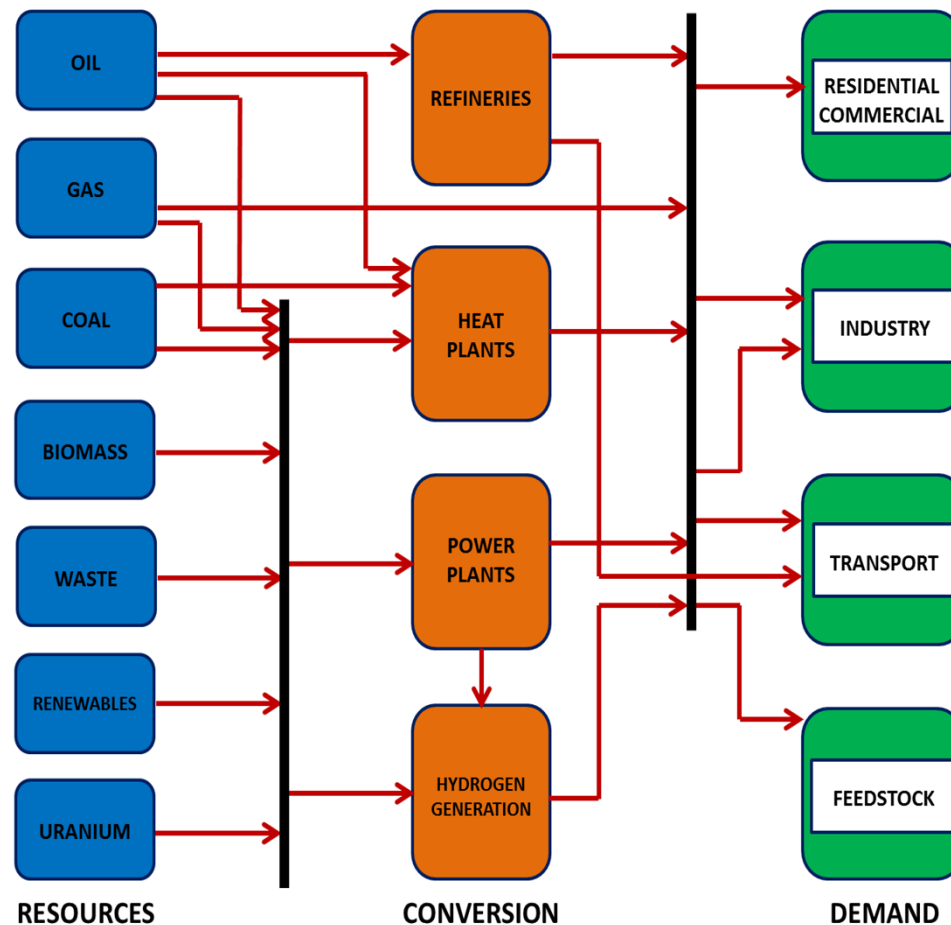

- **Combination of**
 - system-wide and dynamic temporal perspective of EEM, and
 - detailed environmental and human health technology assessment of LCA
- **Expected knowledge gains and insights**
 - Integrated and consistent assessments of energy systems
 - Analysis of co-benefits and trade-offs between sustainability aspects of energy systems
 - Insights for energy policy-making

- Motivation
- Methodologies and concept
- Integration of Global MARKAL model and LCA
- Outlook

Developing, quantifying and analyzing scenarios of the global energy system

- **Global**

- All energy sectors
- All energy resources

- **Multi-regional**

- 15 world regions
- Trade (not for electricity)

- **MARKAL**

- Bottom-up, technology rich (> 300)
- Perfect-foresight (2010 - 2100)
- Least cost optimization
(Total discounted system costs)

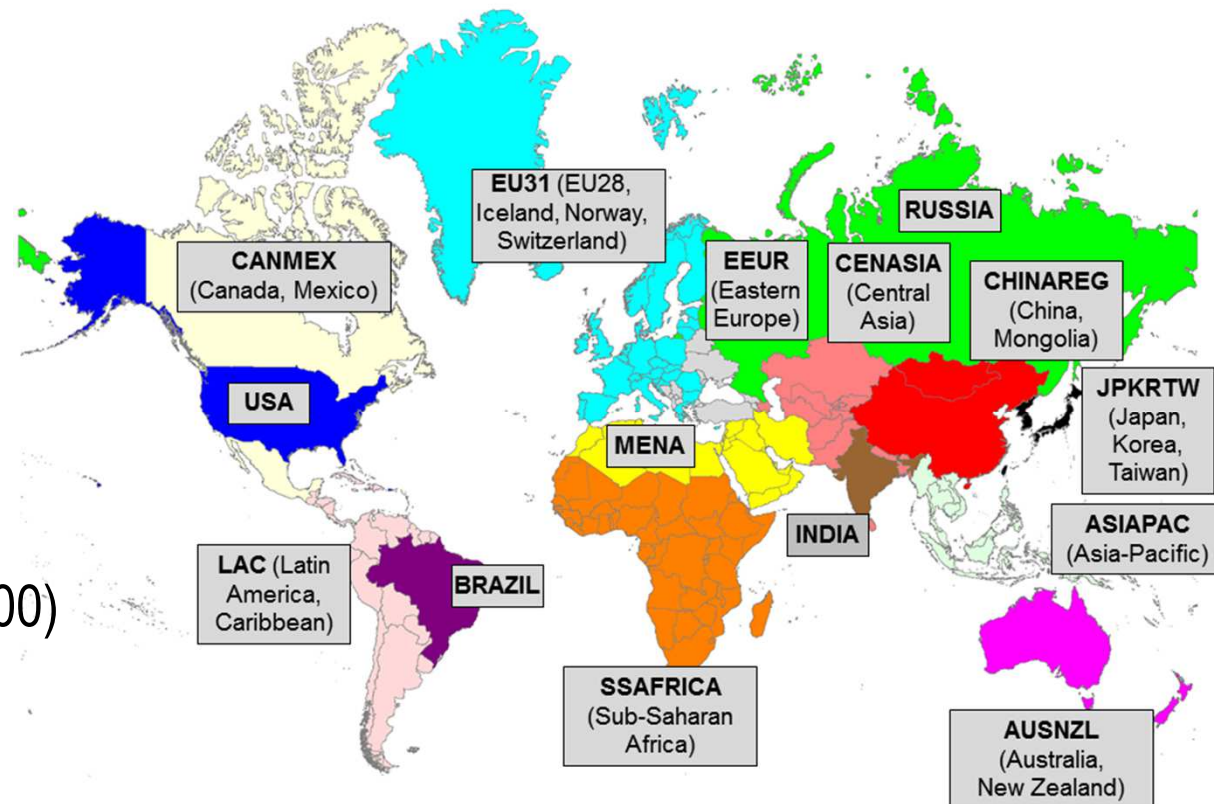

Sub-ordination of the integrated models

Economy

- Education
- IT & Communication
- Entertainment
- Services
- Retail trade
- Real estate activities
- Accommodation
- ...

ecoinvent

- Construction
- Plastics
- Metals
- Waste treatment
- ...

GMM model

- Energy crops
- Fuel mining
- Fuel production
- Electricity
- Transport
- ...

Integration of GMM model and LCA

ecoinvent

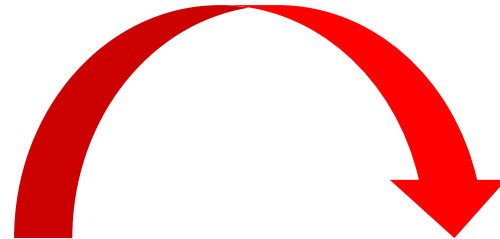
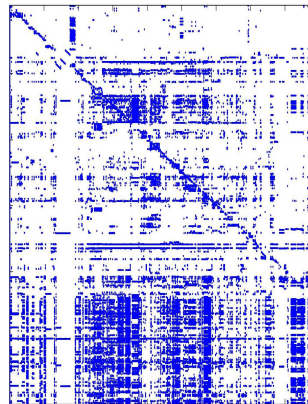

GMM model

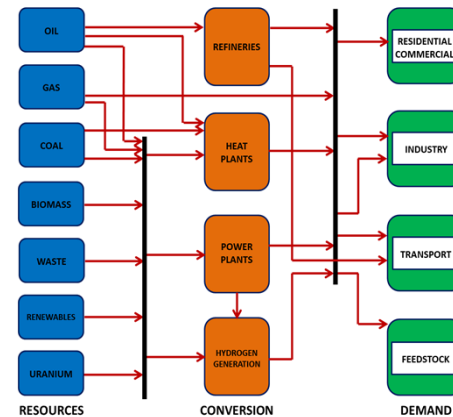
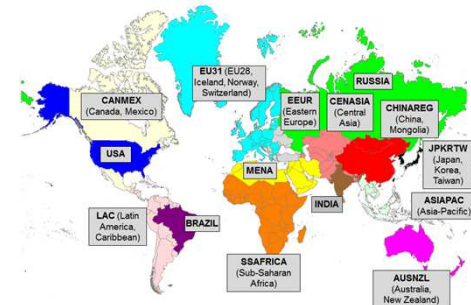

Concept of integrating ecoinvent data in the GMM model

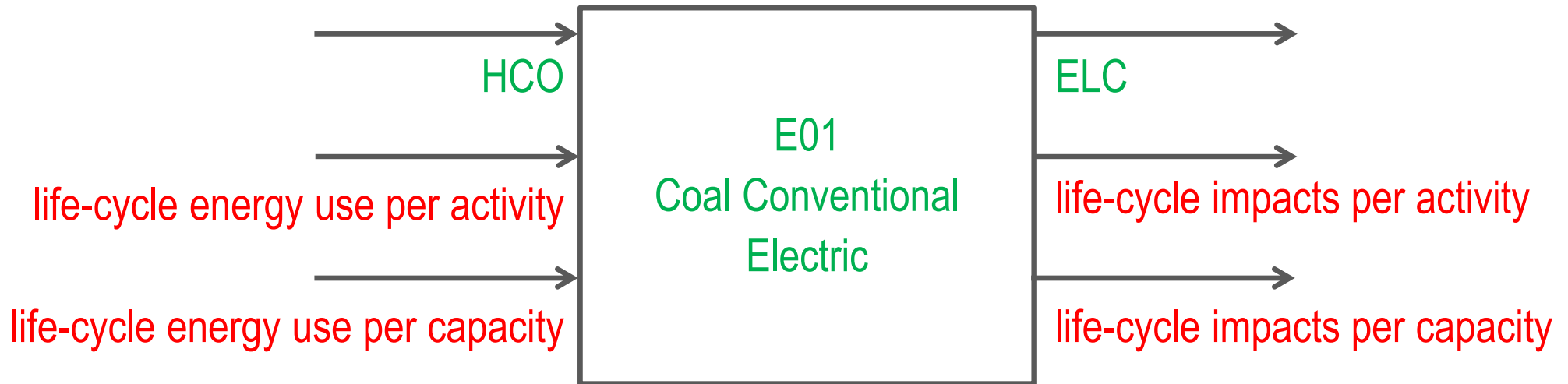

→ (4 flows) x (>300 processes) x (15 regions)

Allocation of an ecoinvent dataset to each GMM process

GMM process	GMM description	ecoinvent v3 name	ecoinvent v3 regions
S12	Lignite Extraction	Lignite mine operation	RER, RoW
E01	Coal Conventional Electric	Electricity production, hard coal	ASCC, AT, AU, BA, BE, BG, BR, CA-AB, CA-NB, CA-NS, CA-ON, CL, CN, CZ, DE, DK, ES, FI, FR, FRCC, GB, HICC, HR, HU, IE, IN, IT, JP, KR, MRO, MX, MY, NL, NO, NPCC, PE, PL, PT, RFC, RO, RoW, RU, SE, SERC, SI, SK, SPP, TH, TR, TRE, TW, TZ, UA, WECC, ZA
...

Definition of the life-cycle impacts per activity and per capacity

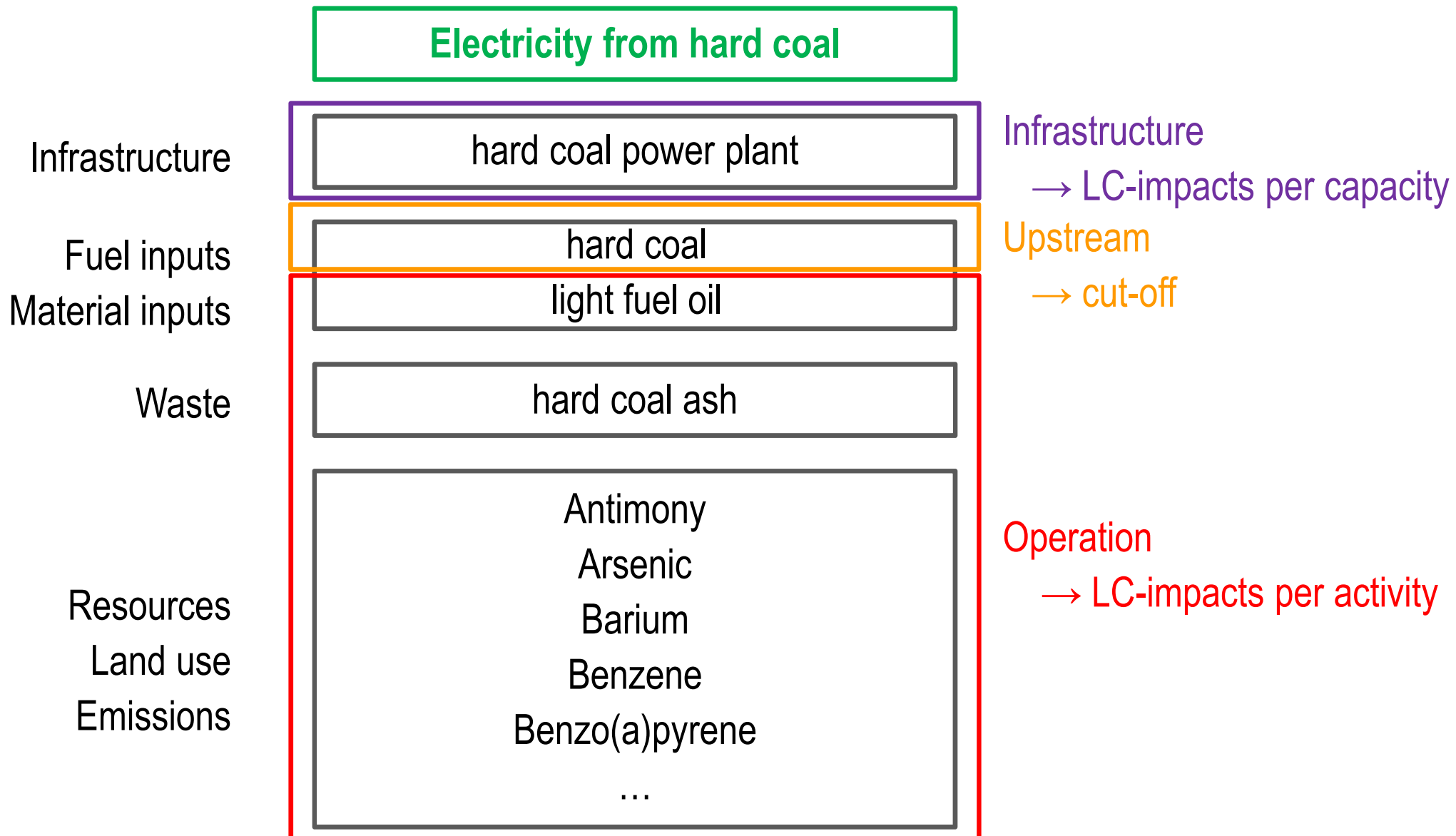

Definition of the life-cycle energy use per activity and per capacity

- Electricity
- Heat
- Transport

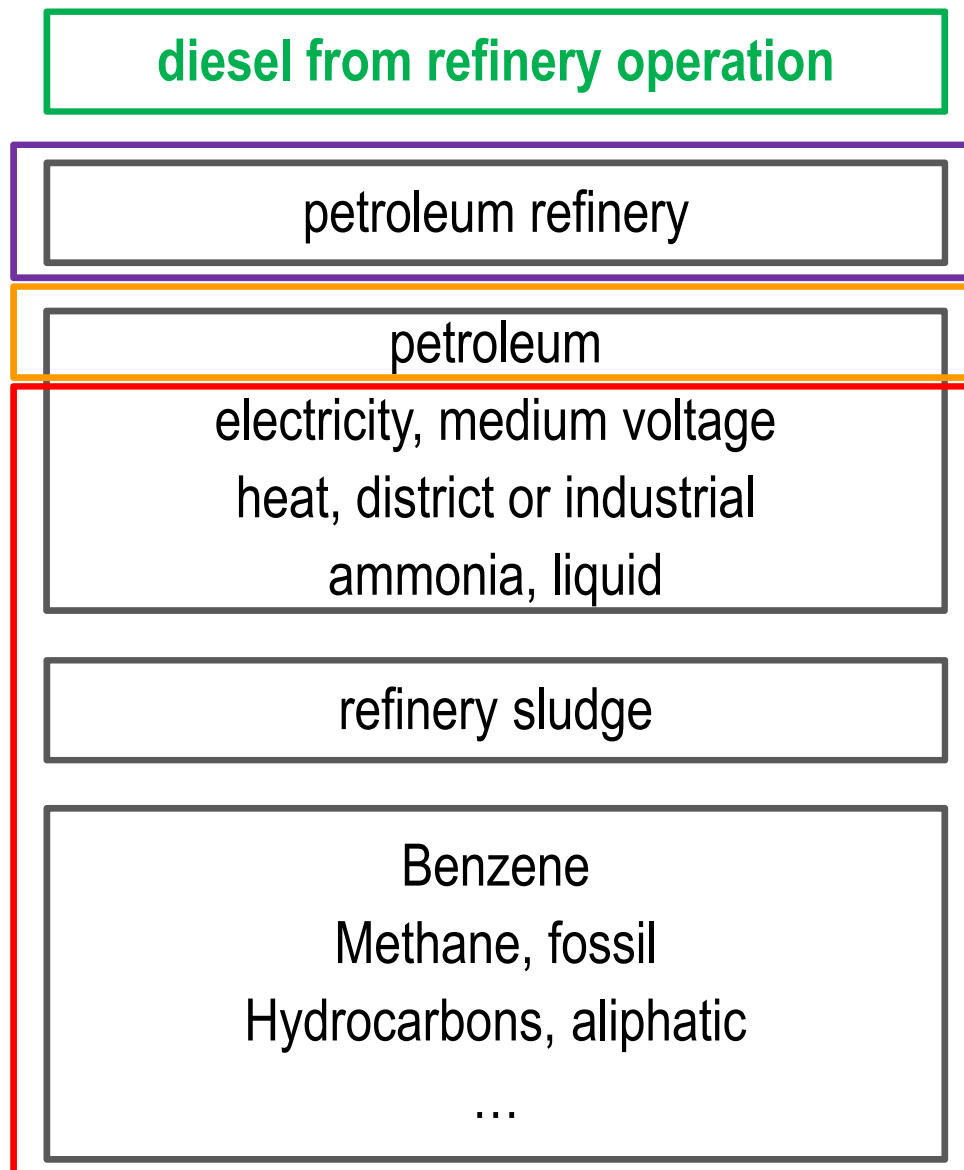

Infrastructure
→ LC-energy use per capacity

Upstream
→ cut-off

Operation
→ LC-energy use per activity

Regional harmonization

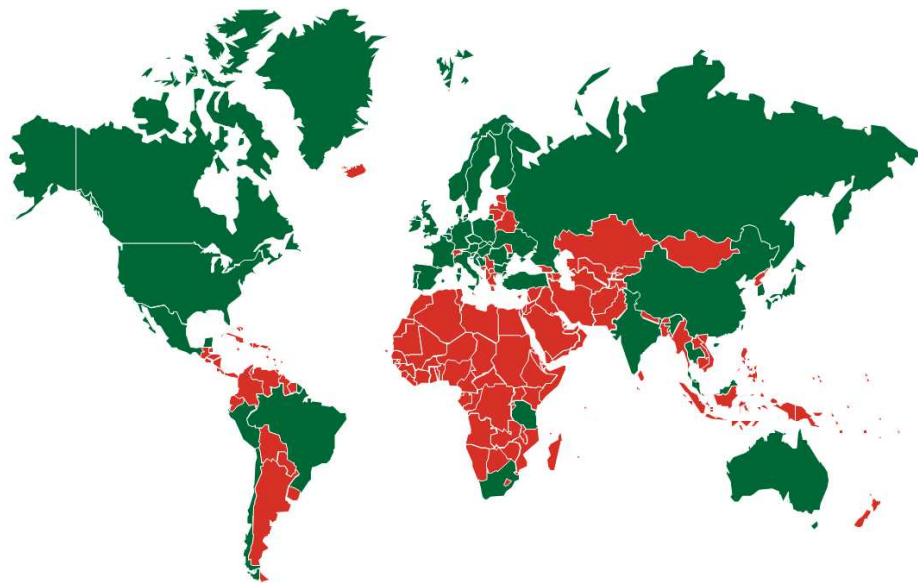

Regional coverage for E01 in ecoinvent v3

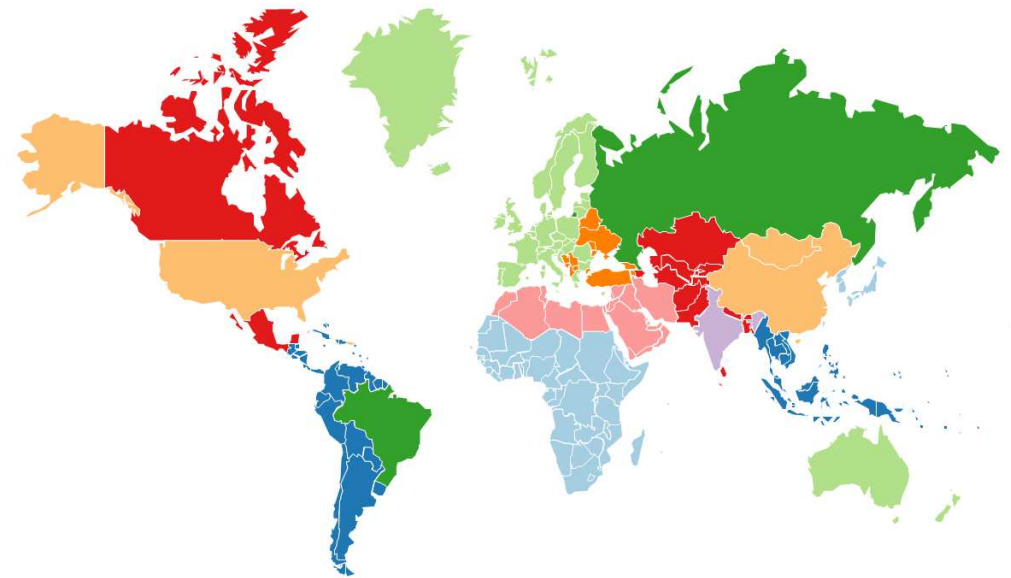

Regional coverage for E01 in GMM model

Update of v2 datasets to v3

- ecoinvent v2 (direct linking)

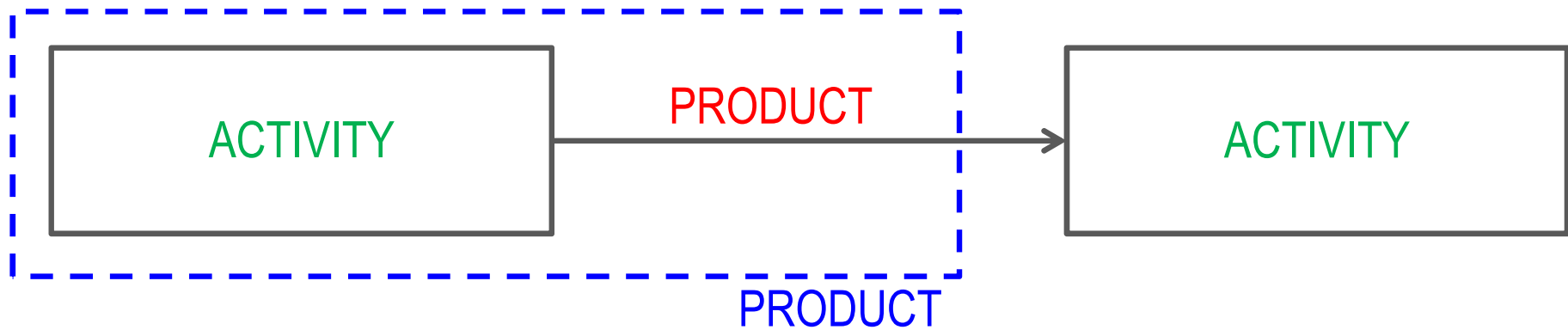

- ecoinvent v3 (indirect linking)



Ex-post assessment of environmental burdens of delayed climate action scenario

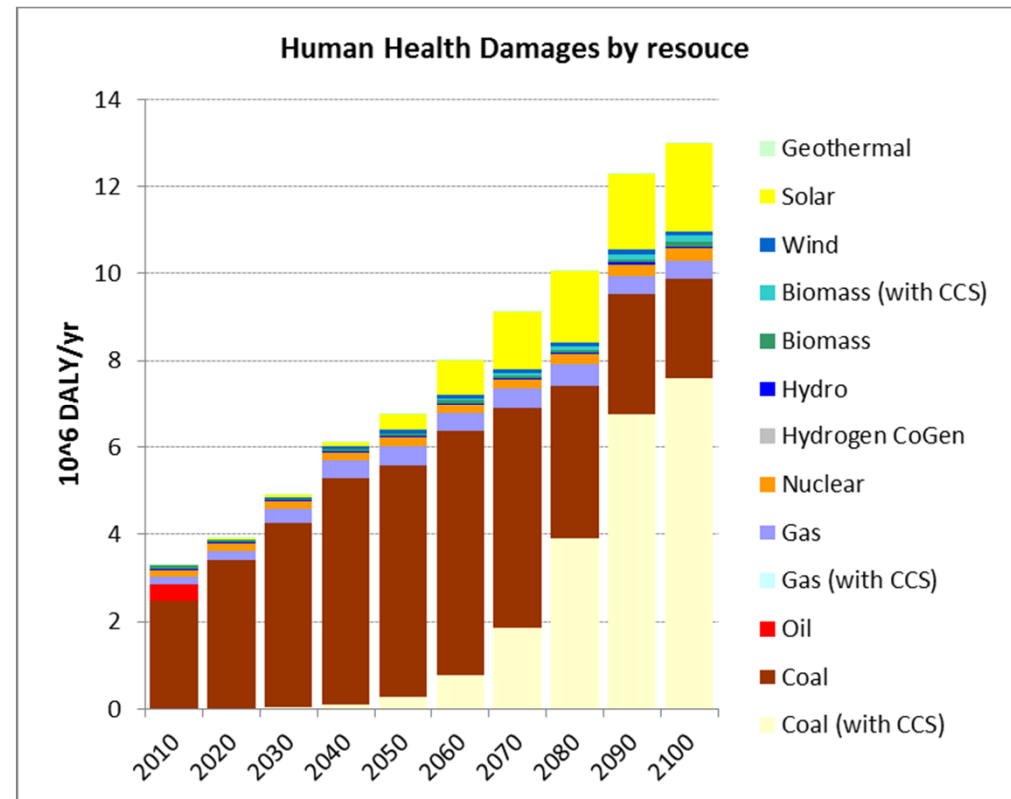
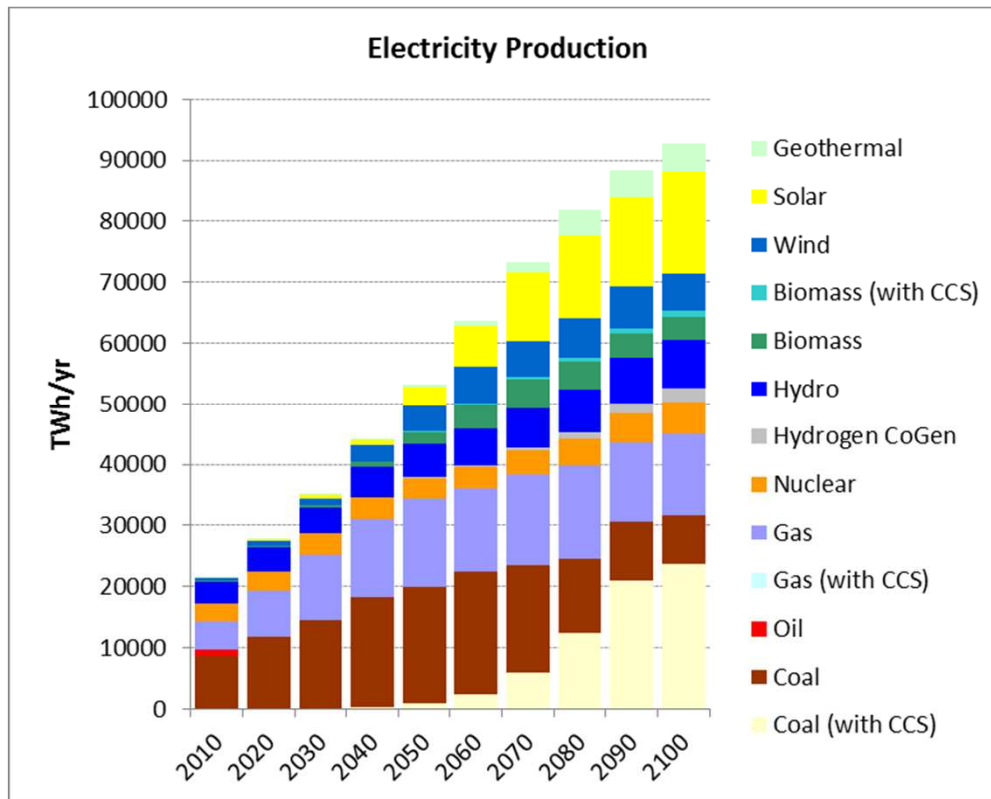

- Current limitations:
 - electricity sector only
 - complete life-cycle calculation (no separation of the processes in the energy chain)
 - exogenous (ecoinvent) energy mixes

- Motivation
- Methodologies and concept
- Integration of Global MARKAL model and LCA
- Outlook

Introduction of external costs to the GMM model

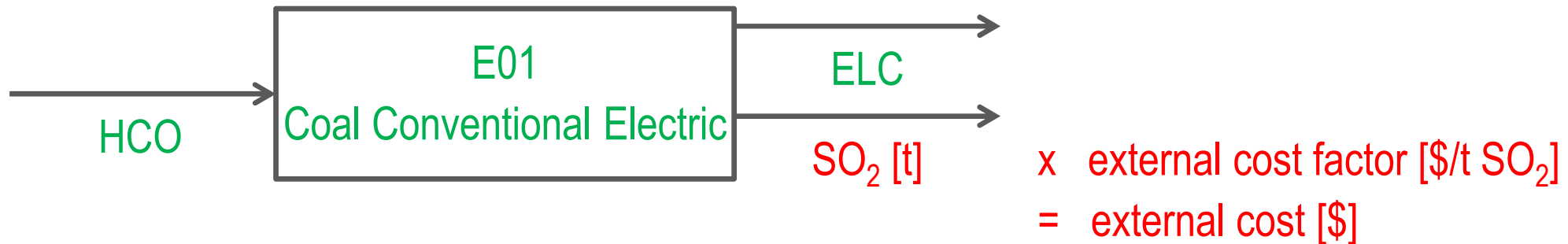

Introduction of other sustainability aspects for Multi-criteria decision analysis (MDCA)

$$\min (\text{cost}) \rightarrow \min (w_1 * \text{INDICATOR}_1 + w_2 * \text{INDICATOR}_2 + \dots)$$



Environment



Economy



Society



Security of Supply

Martin Densing, Chris Mutel & LEA staff



Are there any questions?

