

International Energy Workshop, Cape Town, 28th June 2006

Assessing Wood-Based Synthetic Natural Gas (Bio-SNG) Technologies

Thorsten F. Schulz

L.Barreto, S.Kypreos, S.Stucki

Energy Economics Group

Paul Scherrer Institute (PSI)

Switzerland

Methanation Plant

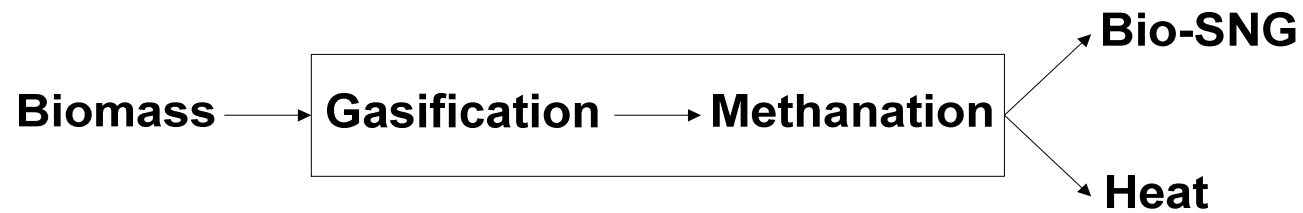

$$\eta_{\text{Bio-SNG}} = 0.55$$

$$\eta_{\text{Heat}} = 0.10$$

Reference Energy System

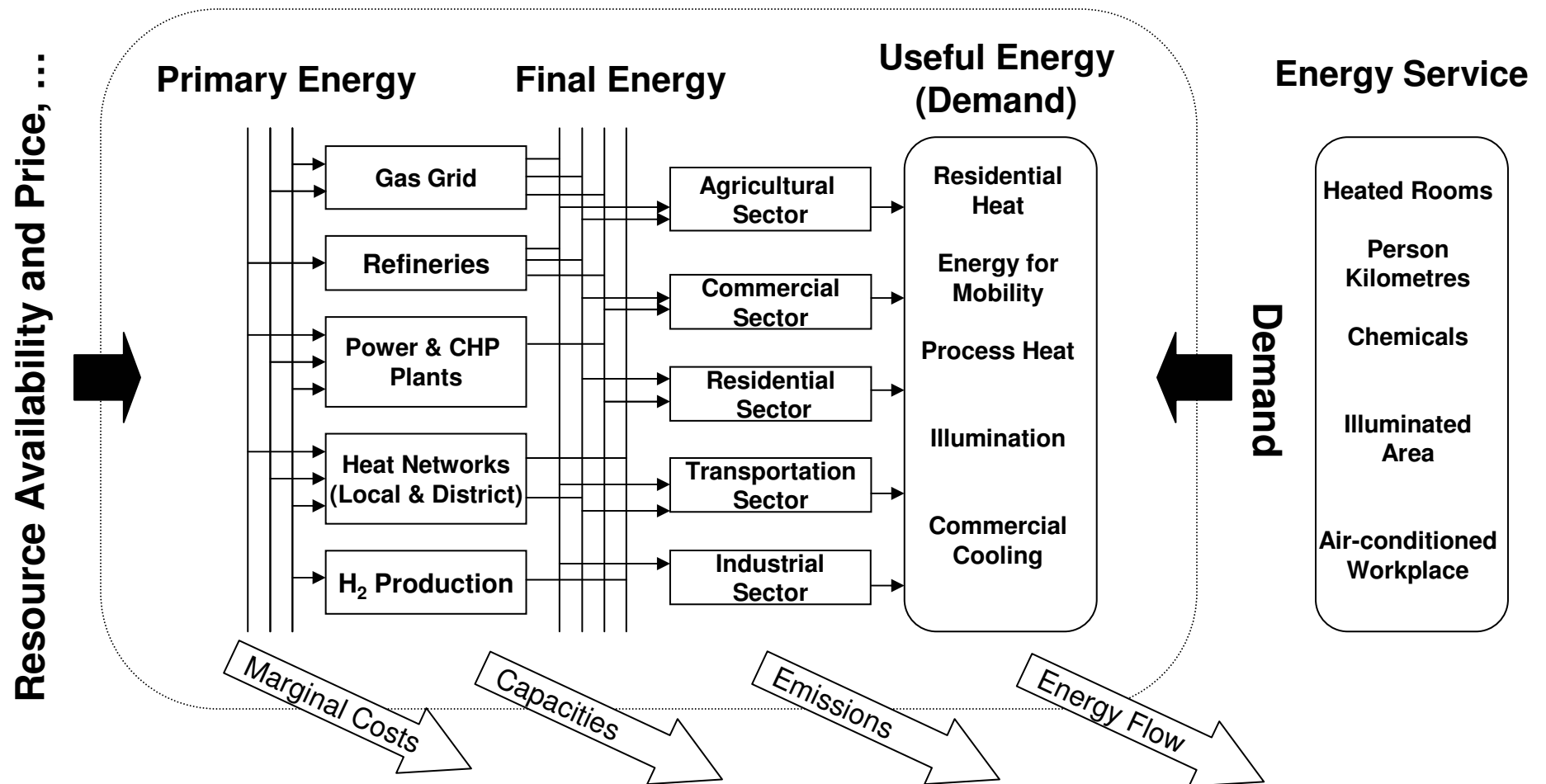

Bio-SNG Implementation

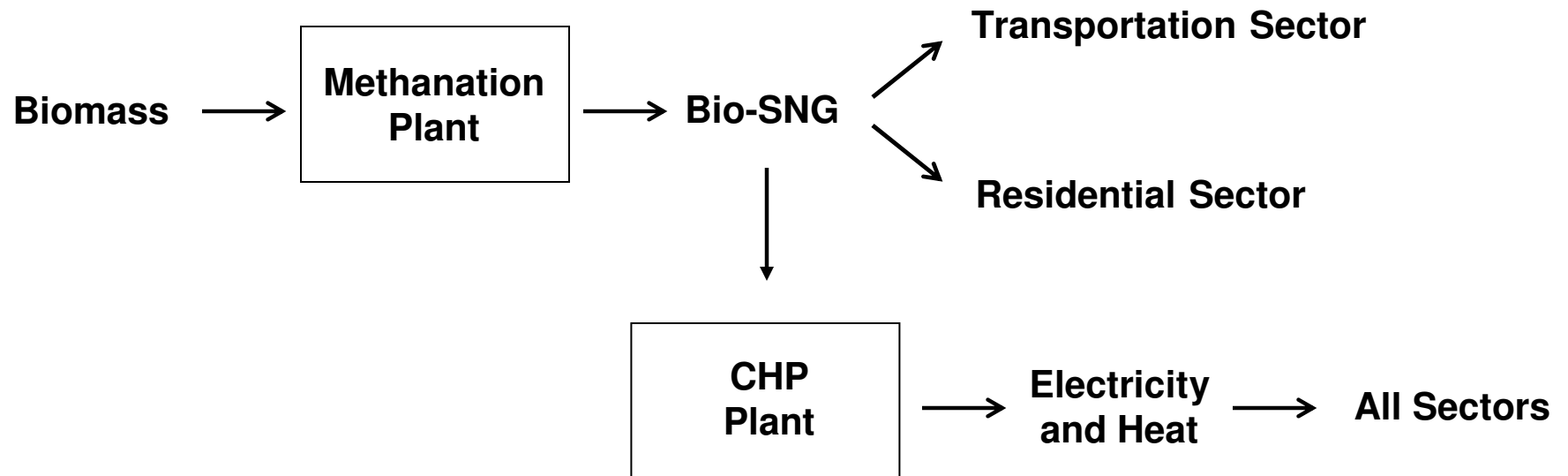

Scope of the Analysis

a) **Baseline : 50 US\$₂₀₀₀/bbl in 2050**

b) **Scenarios**

- **Oil Price : up to 130 US\$₂₀₀₀/bbl in 2050**
- **Bio-SNG Subsidies : up to 10 US\$₂₀₀₀/GJ**
- **Combined Oil Price & Bio-SNG Subsidies**

Biomass 2000

Total theoretical biomass potential ~ 100 PJ

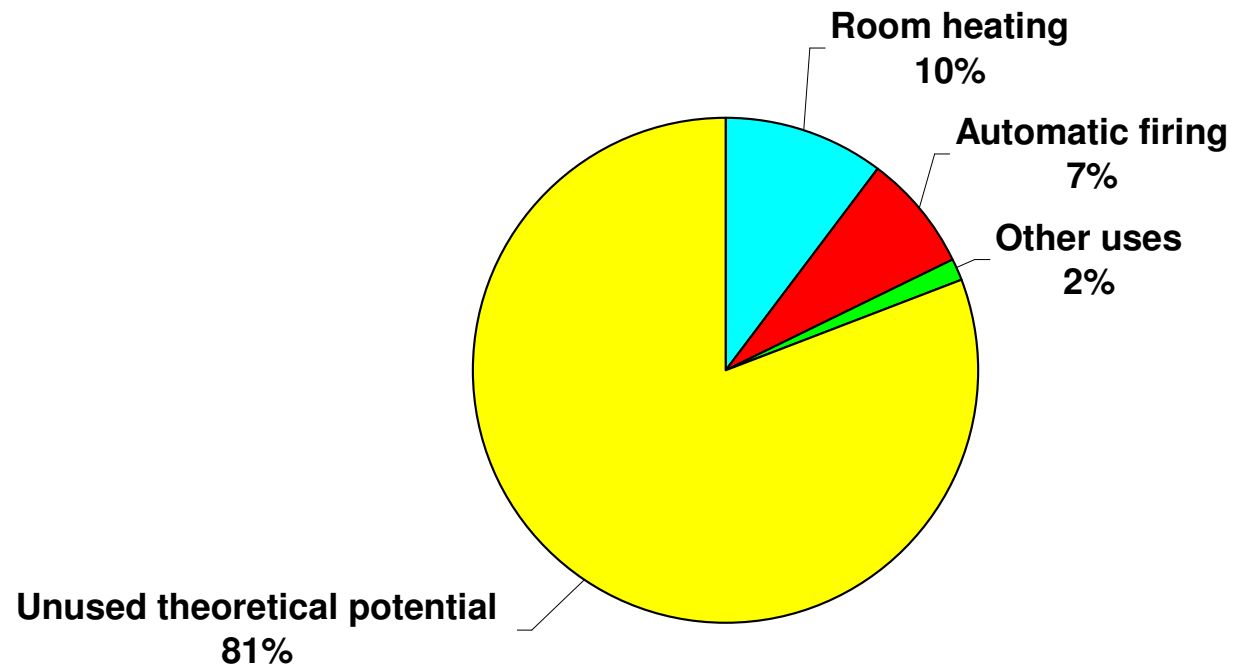

Baseline

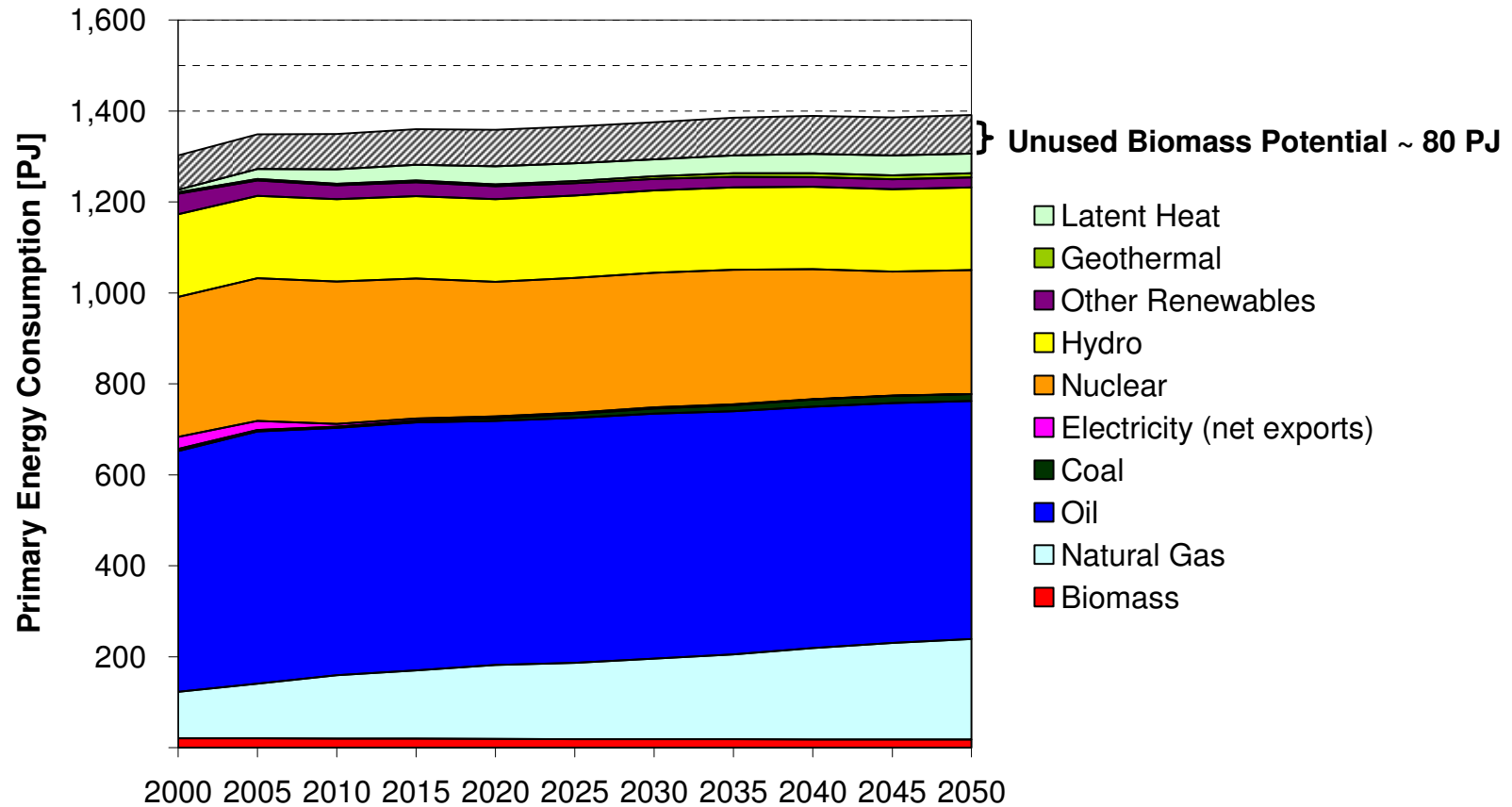

Scenario Sensitivity Analysis

Baseline

**Primary
Consumption [PJ]
Biomass for Methanation**

Oil Price in 2050	Subsidy
110	0
80	3
50	6

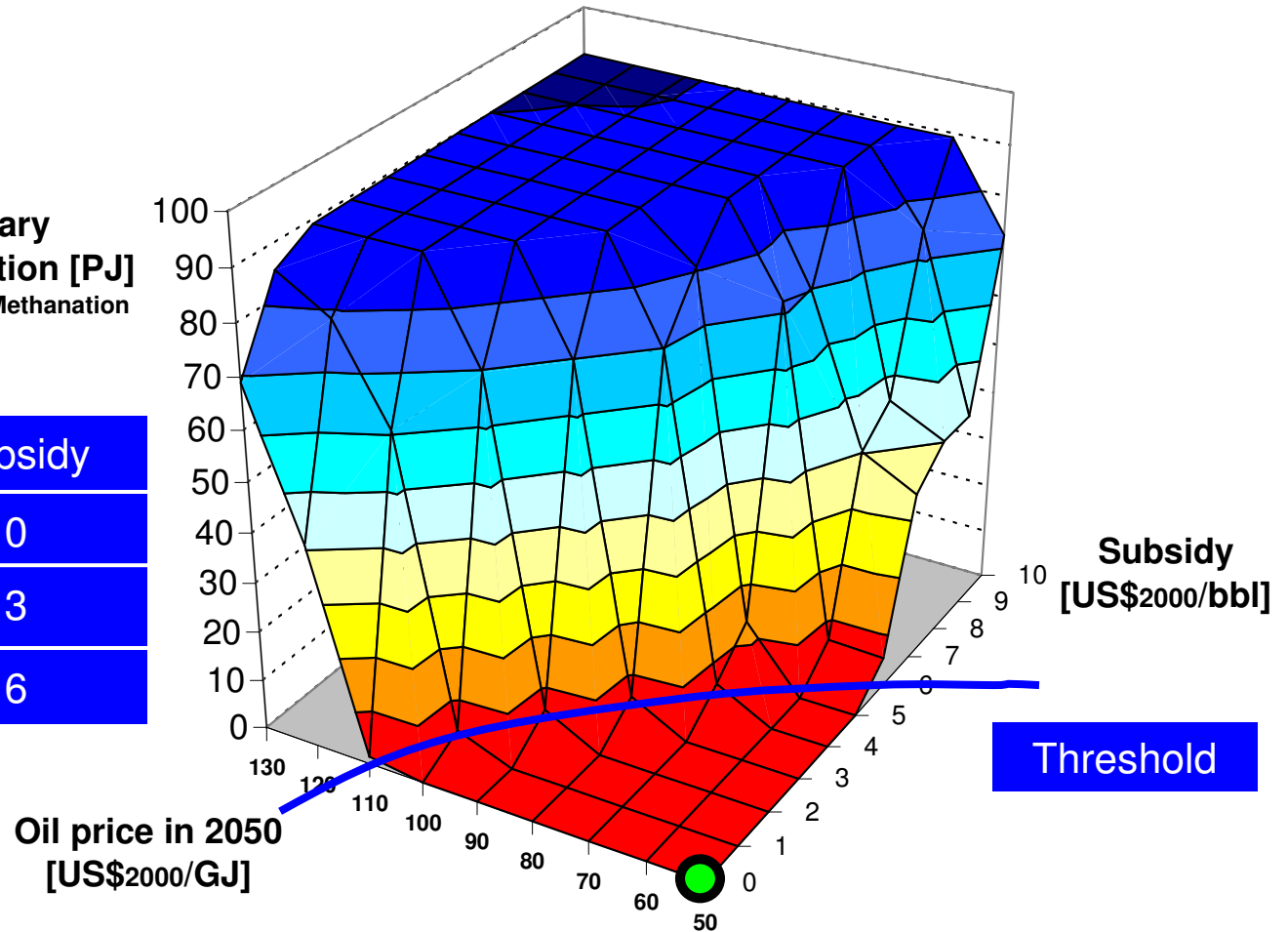

Oil Price - 2050

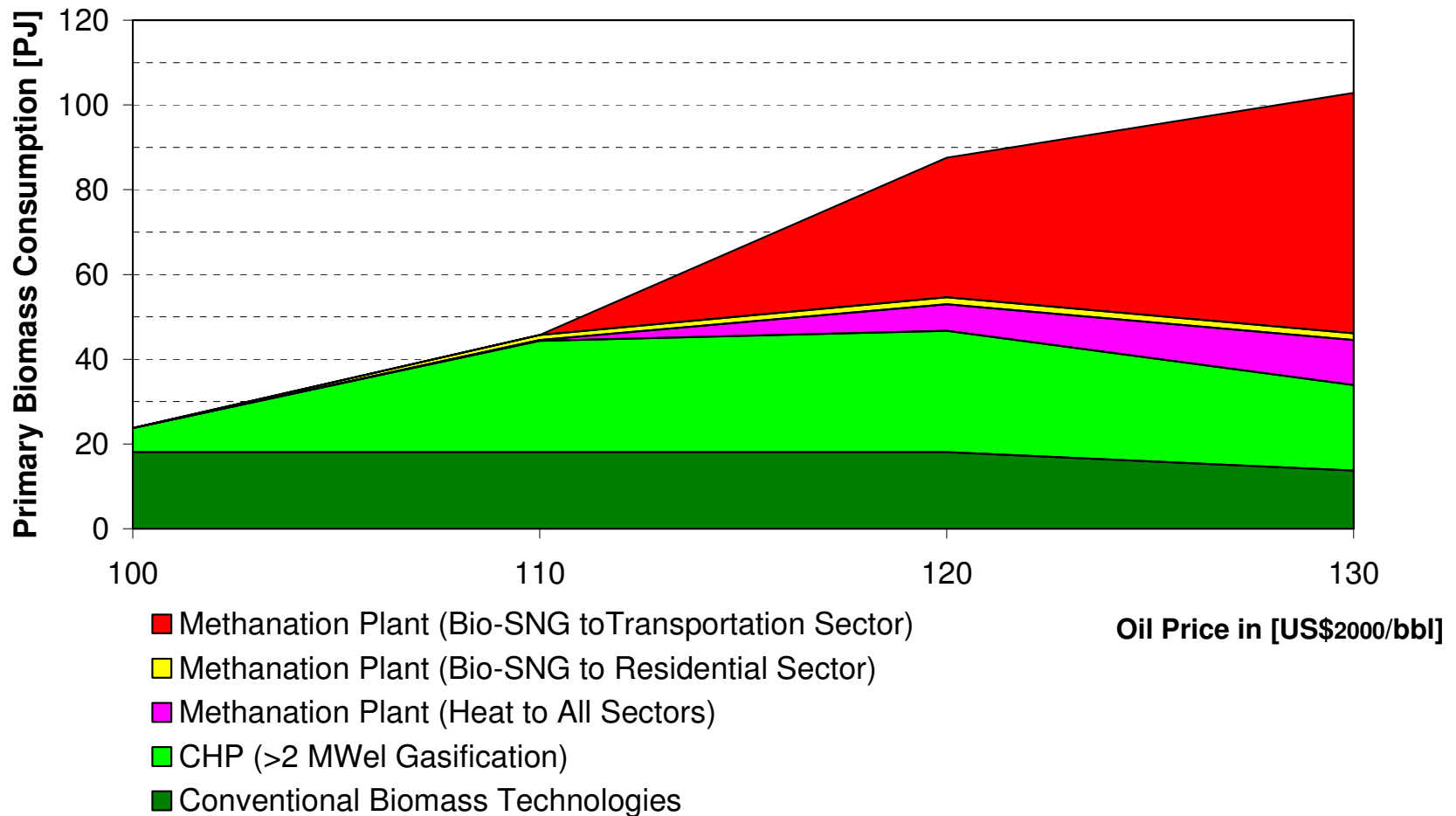

Oil Price - 2050

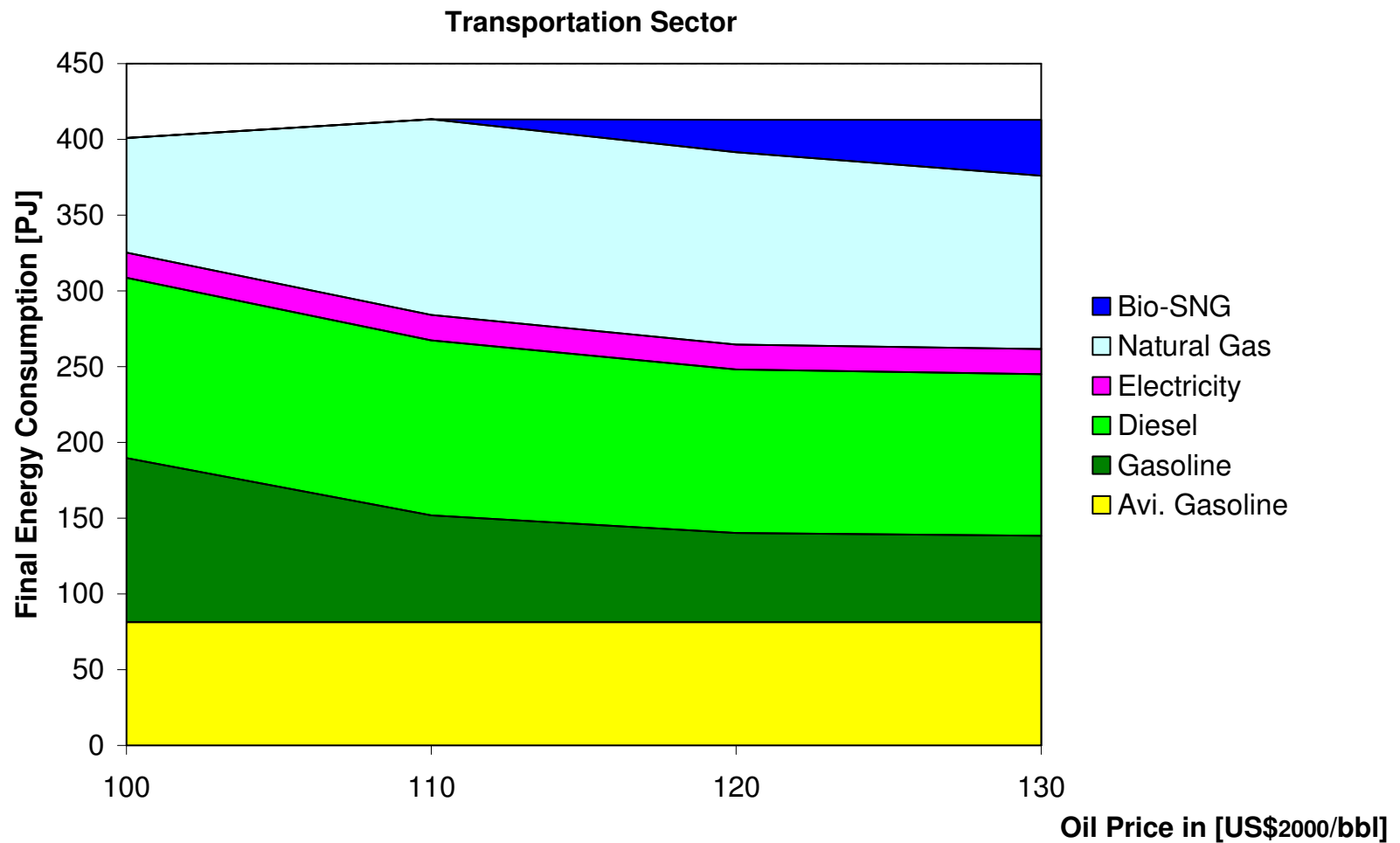

Bio-SNG Subsidy - 2050

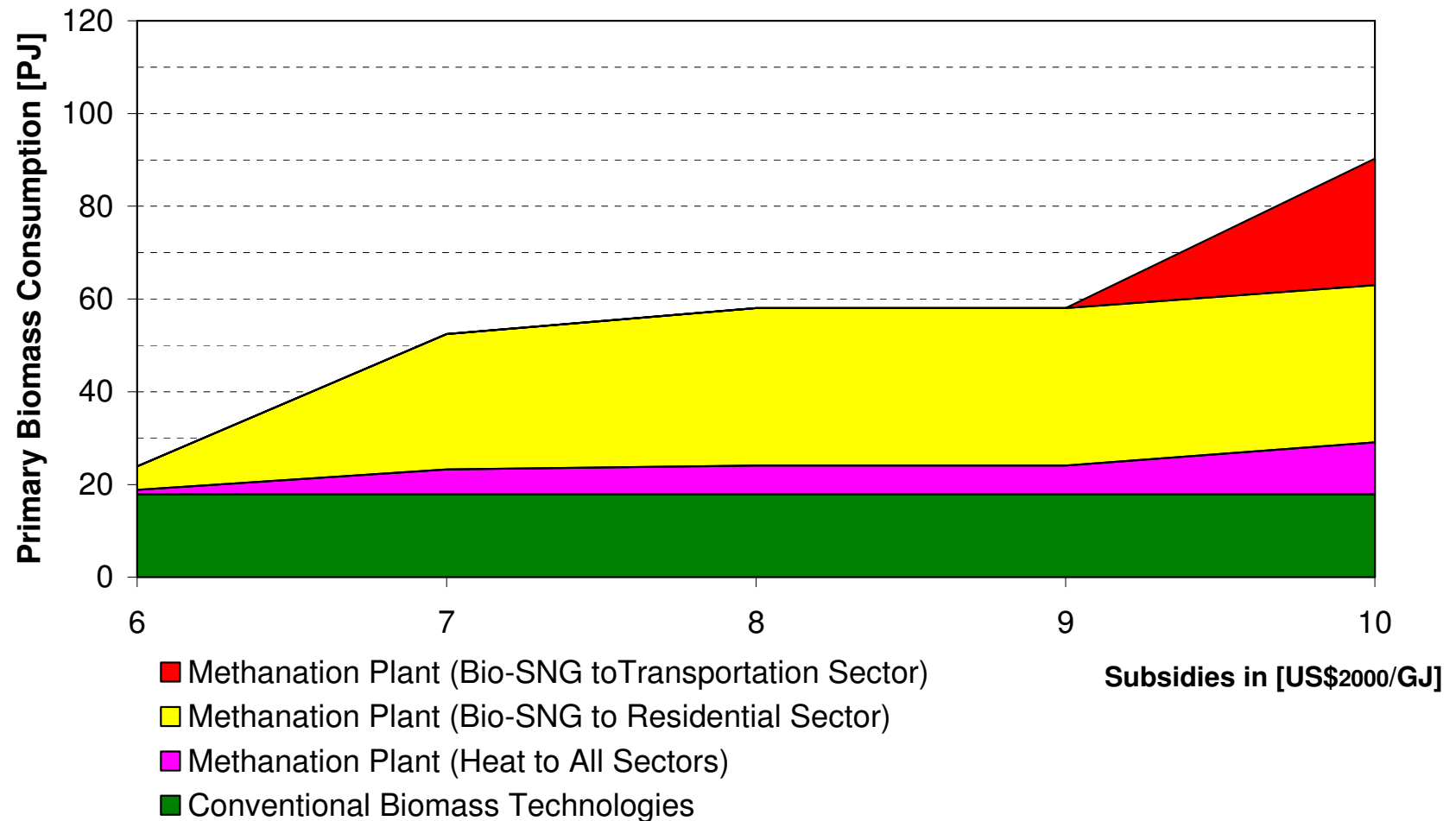

Conclusions

- ✓ A **threshold** for the penetration of wood-based synthetic natural gas technologies is clearly identifiable
- ✓ The use of bio-SNG in the **transportation sector** has a larger potential than in the residential sector
- ✓ **Synergies** between bio-SNG and natural gas could be exploited

Additional: Selected Resource Prices Baseline

	2000	2005	2010	2015	2020	2025	2030	2035	2040	2045	2050
Natural Gas [US\$/GJ]	3.3	3.6	3.8	4	4.3	4.5	4.8	5	5.2	5.5	5.7
Crude Oil [US\$/GJ]	4.6	5	5.3	5.6	6	6.3	6.7	7	7.3	7.7	8
Crude Oil [US\$/bbl]	29	31	33	35	37	39	41	43	45	47	50

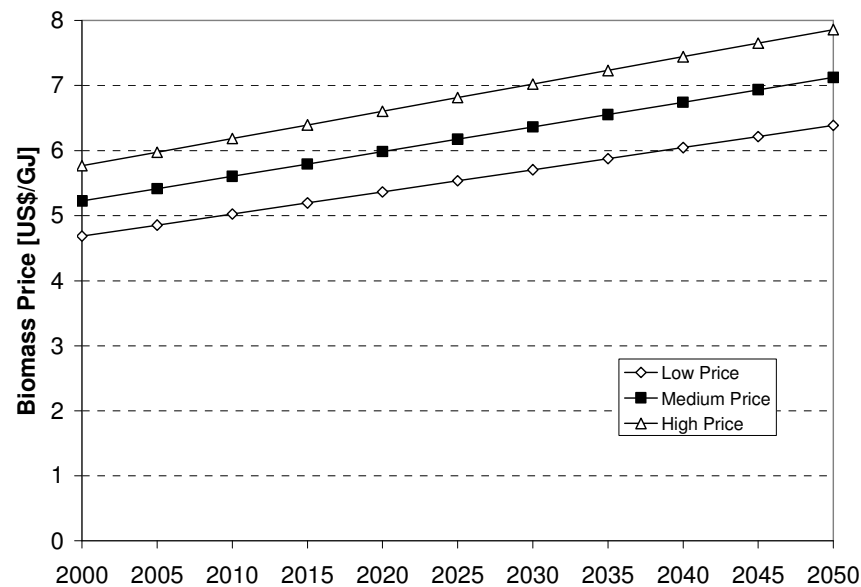

Additional: Methanation Plant II

Total Efficiency	Main Product Efficiency	Thermal Efficiency	Capacity	Investment Costs	Fixed O&M Costs	Variable O&M Costs	Plant Factor	Lifetime	Starting year	Discount Rate
[%]	[%]	[%]	[MW] input	[US/kW] input	[CHF/kW] input	[Rp/kWh] input	[hours/a]	[a]		[%]
65	55	10	100	996	34.9	0.125	8000	15	2010	5

Additional: Chemical Reaction Methanation

Air Gasification



Water Vapor Gasification

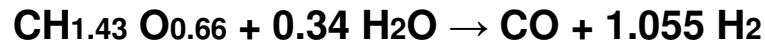

Methanation

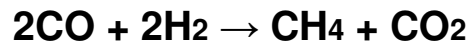
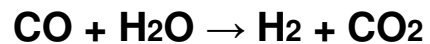
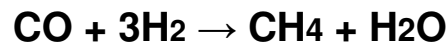

Additional: Bio-fuel Production from Wood

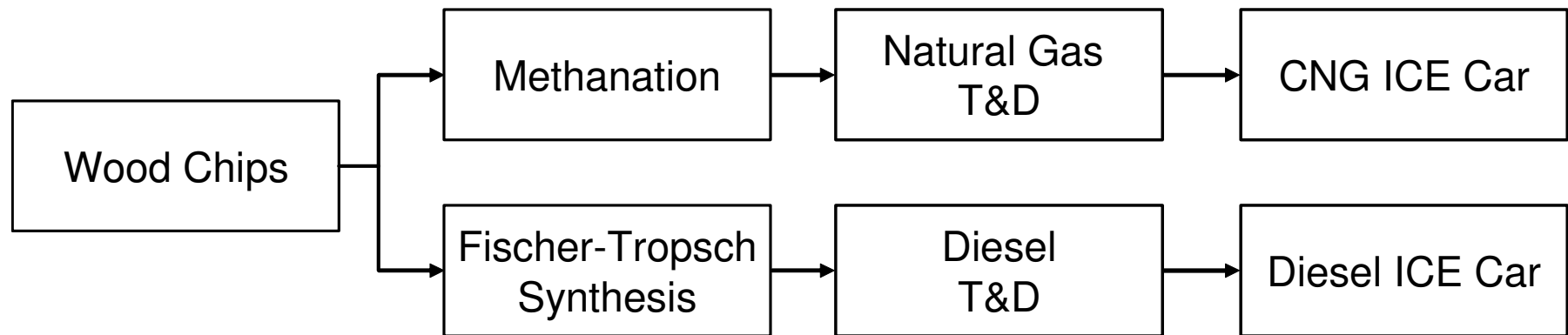

Additional: CHP Production from Wood

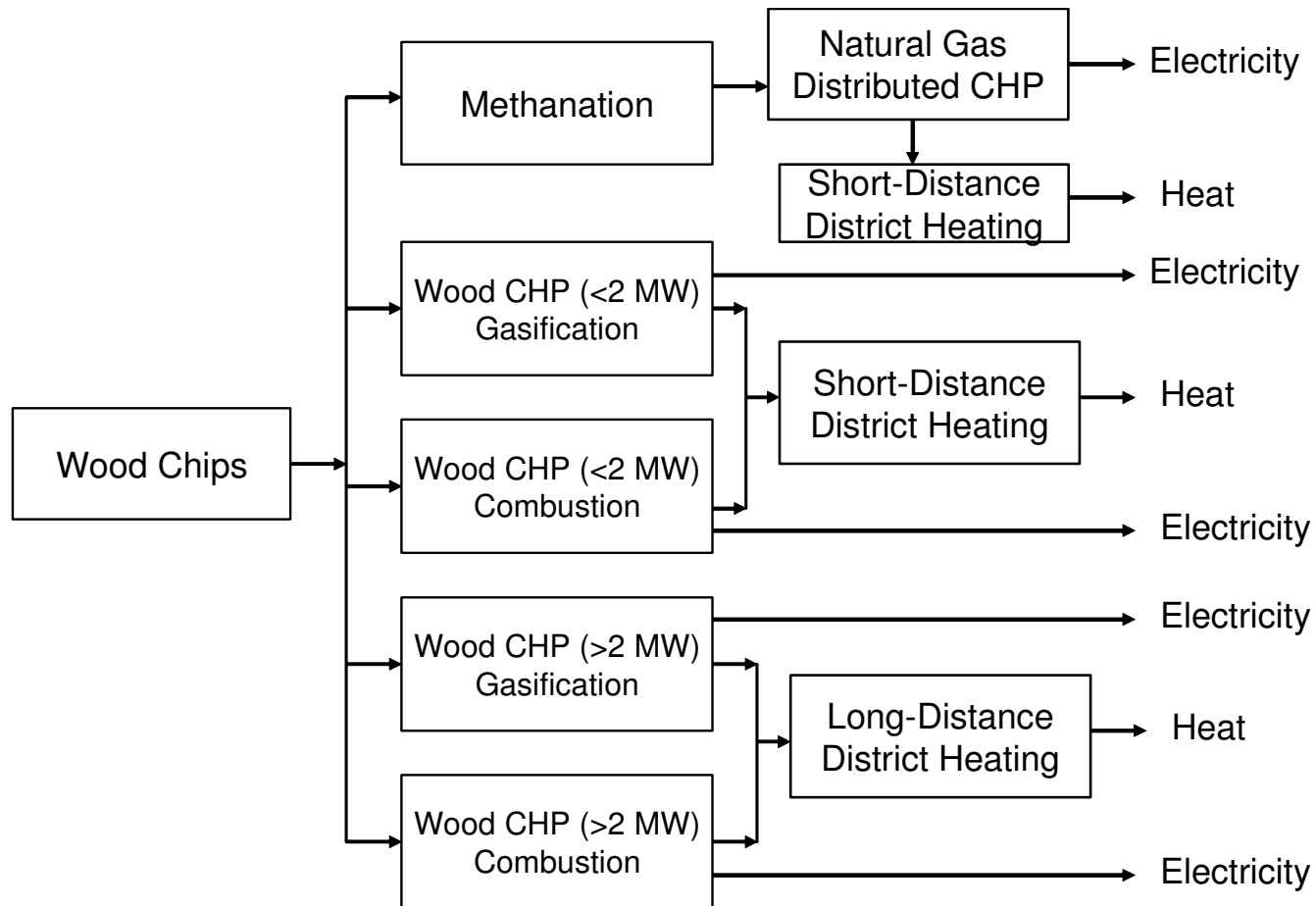

Additional: Heat Production from Wood

